



in-dye® Indoor

7.3 cm² version specifications (ver. 2.4)



Sustainable



High performance



Robust

The in-dye® Indoor PV cell is tailored for indoor use (20 – 10,000 lux), and for integration into Internet of Things (IoT) devices. They are specifically designed to power self-sustaining, energy-efficient electronics in indoor environments but can also be used outdoor. These ultra-thin PV cells can be customized in size and shape to meet the unique needs of our customers in terms of integration.

The indye® Indoor PV cell is optimized to convert light from LED and CFL lamp source regardless its temperature. Depending on conditions, in-dye® Indoor technology can harvest and convert indoor light with efficiencies up to 25 %.

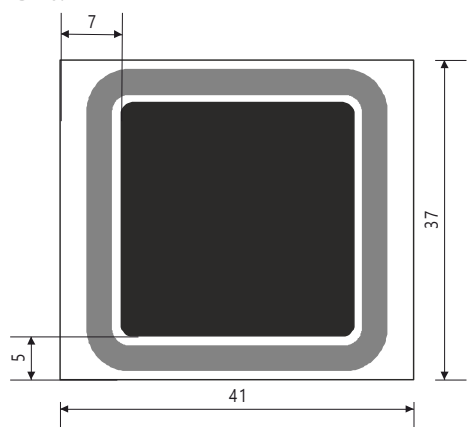

	Min	Max
Light intensity (lx)	20	10 000
Operating temperature (°C)	-20	40
Ideal absorbance (nm)	360	650
Thickness (mm)	2.2	

(Active area* = 7.3 cm²)

* Can be specifically designed as per customer requirements

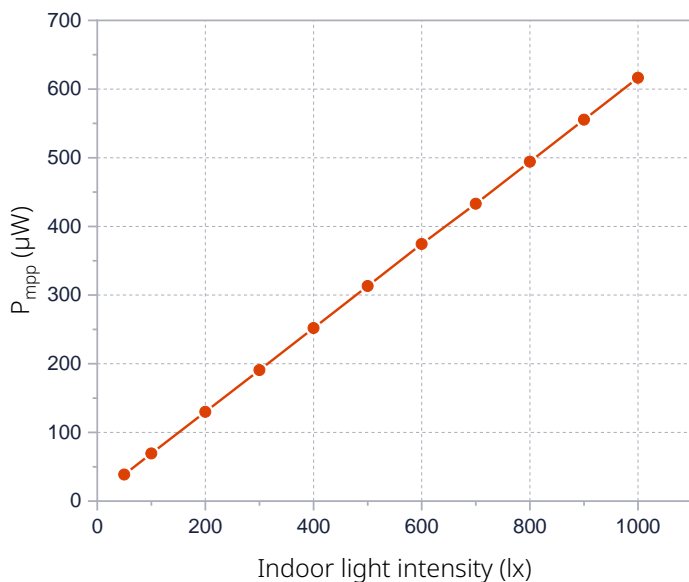

Intensity (lx)	P _{mpp} (µW)	P _{mpp} (µW/cm ²)
50	39	5.3
100	69	9.5
200	130	18
300	191	26
400	252	35
500	313	43
600	374	51
700	433	59
800	494	68
900	555	76
1000	617	85

The data reflect the performance of a single in-dye® Indoor PV cell at 25 °C, under LED illumination 3000 K, unless otherwise specified.

Voltage at open circuit and at maximum power point of in-dye® Indoor PV cell

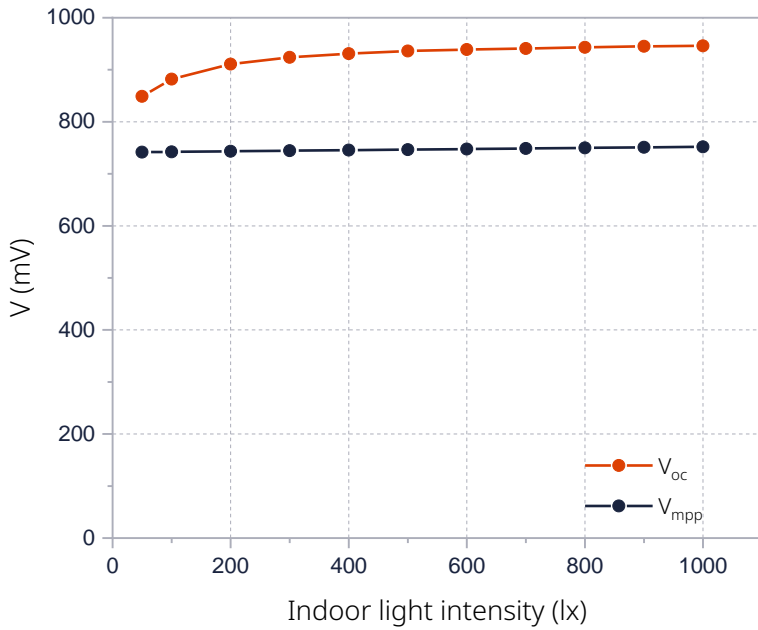

Intensity (lx)	V_{oc} (mV)	V_{mpp} (mV)
50	849	742
100	882	742
200	911	743
300	924	744
400	931	746
500	936	747
600	939	748
700	941	749
800	943	750
900	945	751
1000	946	752

Current at short circuit and at maximum power point of in-dye® Indoor PV cell

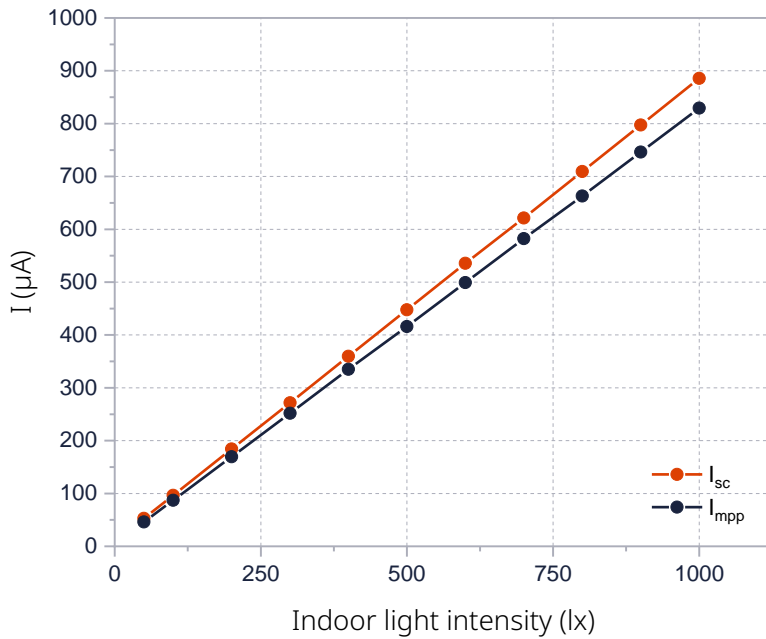

Intensity (lx)	I_{sc} (µA)	I_{mpp} (µA)
50	53	46
100	97	87
200	184	170
300	272	252
400	360	335
500	448	416
600	534	499
700	621	582
800	709	663
900	798	746
1000	886	829

Stability of in-dye® Indoor PV cell

(measurements at 1000 lux, LED 2700 K)

Stability under real indoor condition

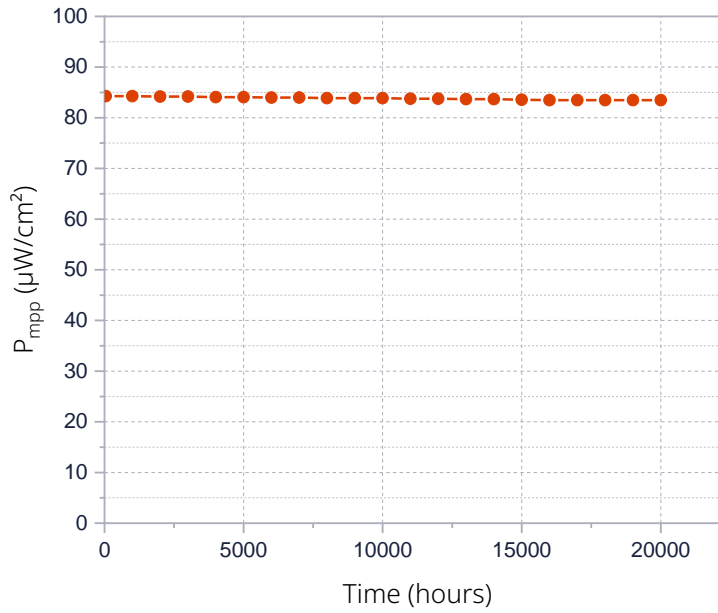

Stability under 100 % relative humidity at 40 °C

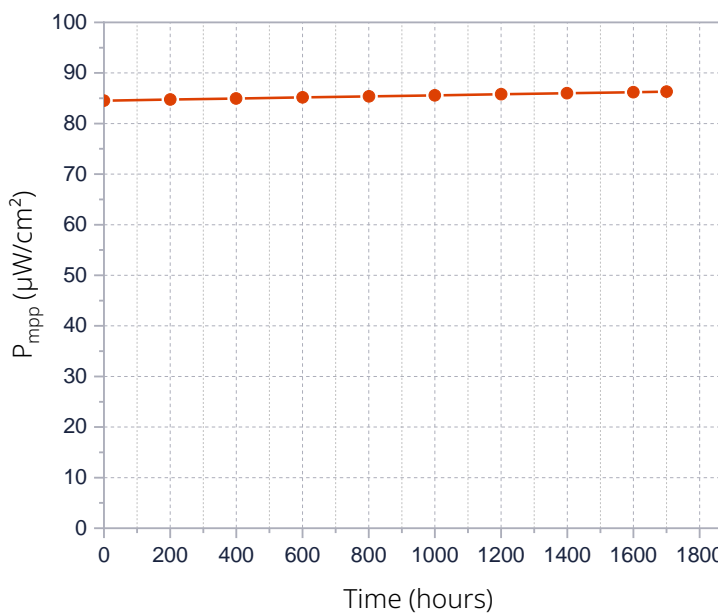

in-dye® *Indoor* PV cell compared to commercialized Indoor PV technologies

(Comparison data are given as indications)

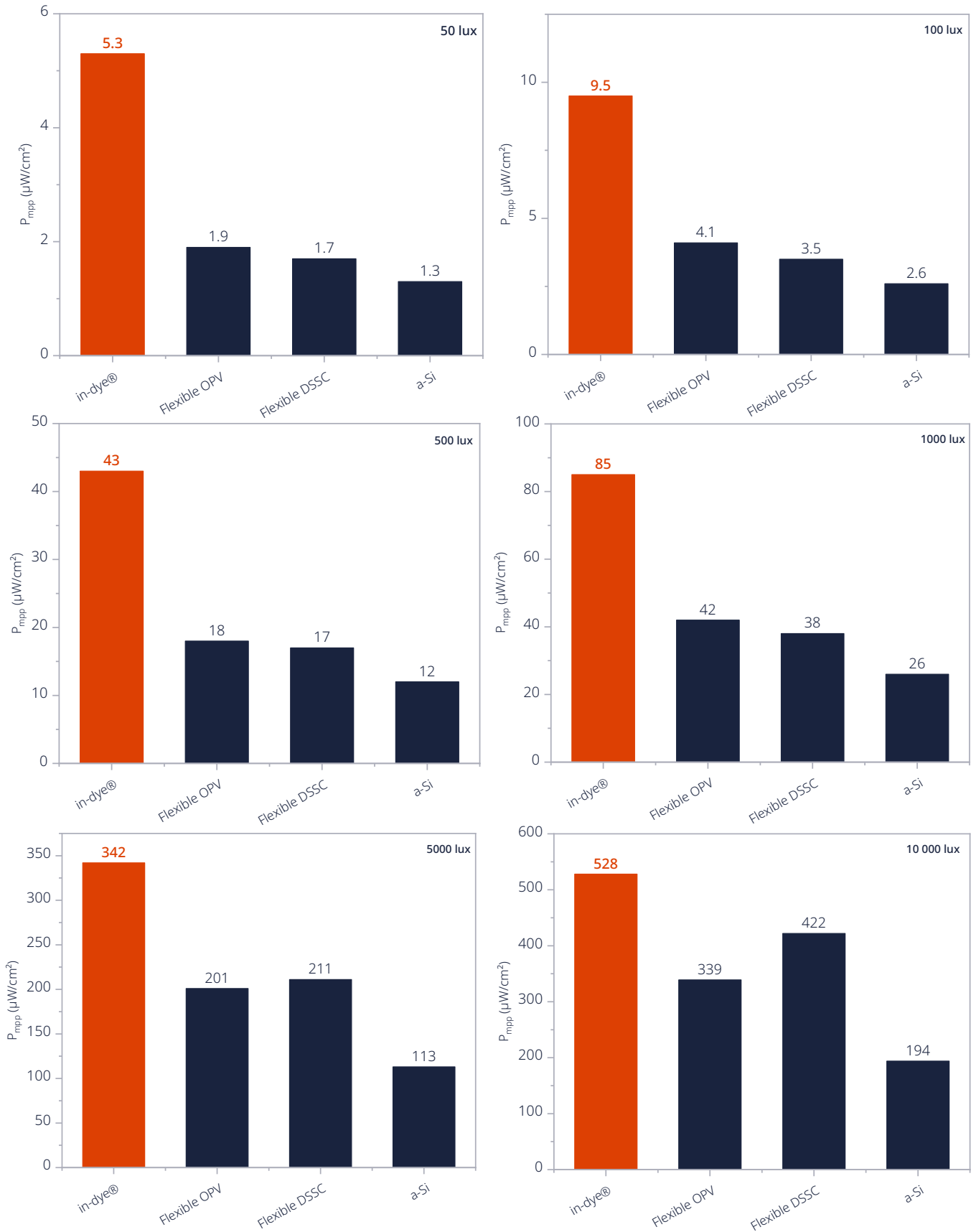

For more information about customization and integration options, or if you want to test our product, please get in touch with our team:

contact@g-lyte.com

+33 (0) 7 69 68 38 05